

Nach Auftrag Spezielle Lager und Rollen

Spezielle Lager und Rollen – Bezeichnung VLM

Bezeichnung des speziel- len Lagers	Abb.	Abmessungen						Käfig	Scheiber	Gewicht	Tragzahl	
		d	D	B	C	d ₁	R				dynamisch C _r ^{*1)}	statisch C _{0r} ^{*1)}
		[mm]								[g]	[N]	
VLM 003	1	25	42	28	35	8,4	-	2TNH	2RSR	253,8	8 800	6 630
VLM 001		25	36	29	31	8,3	-	2TNH	2RSR	158,7	8 800	6 630
VLM 002 ♦	2	25	47	21	44	-	-	2TNH	2RSR	262,9	20 580	12 430
VLM 006 ♦	3	5	15	5	-	-	-	J	-	4,19	1 880	680
VLM 078	4	8	20	4	-	-	-	TNH	-	5,83	1 890	1 050
VLM 007		9	20	5	-	-	-	TNH	-	5,96	2 270	960
VLM 056		9	21	6	-	-	-	TNH	-	6,96	2 500	1 340
VLM 008	5	10	28	8	9	-	-	J	2RSR	24,8	5 100	2 370
VLM 009 ♦	6	7	24	7	16	6	-	TNH	2ZR	21,2	2 280	990
VLM 010	7	20	42	29	30	-	-	-	2RSR	174,4	15 120	8 350
VLM 011	8	9	24	7	-	-	-	TNH	2RSR	15,6	2 280	990
VLM 012	9	12	36	12	10	-	-	J	2ZR	59,9	6 890	3 090
VLM 013 ♦	10	7	23	7	13	M5	-	J	2ZR	21,6	3 140	1 250
VLM 014 ♦	11	5	22	6	9,5	-	-	TNH	-	6,8	1 880	680
VLM 043	12	5	16	5	-	14,9	1	J	2ZR	4,43	1 430	681
VLM 044		5	16	5	-	14,9	1,5	J	2ZR	4,36	1 430	681
VLM 067		8	22	7	-	21,2	1,25	J	2RSR	12,24	2 500	1 340
VLM 015		8	24	7	-	23,1	1	J	2RSR	15,1	2 500	1 340
VLM 072		8	24	7	-	22,8	1,35	J	2RSR	14,8	2 500	1 340
VLM 096		8	24	7	-	22,8	1,35	J	2ZR	14,8	2 500	1 340
VLM 097		8	24	7	-	23	0,85	J	2ZR	14,8	2 500	1 340
VLM 108		8	24	7	-	22,8	2,05	J	2ZR	15,04	2 500	1 340
VLM 102		8	24	7	-	23,1	1	J	2ZR	15,42	2 500	1 340
VLM 036		10	30	9	-	28,4	1,2	J	2RSR	31,9	5 100	2 370
VLM 045		10	30	9	-	28,4	2	J	2RSR	31,61	5 100	2 370
VLM 082		13	3	10	4	-	9,5	-	J	2ZR	1,52	490
VLM 083	5		16	5	-	15,2	-	J	2ZR	4,61	1 430	735
VLM 125	7		22	7	-	20,2	-	J	2ZR	11,92	2 500	1 340
VLM 047	8		22	7	-	21,1	-	J	2ZR	11,63	2 500	1 340
VLM 055	8		22	7	-	20,2	-	J	2ZR	11,27	2 500	1 340
VLM 084	8		22	7	-	20,7	-	J	2ZR	11,48	2 500	1 340

Nach Auftrag Spezielle Lager und Rollen

Spezielle Lager und Rollen – Bezeichnung VLM (Fortsetzung)

Bezeichnung des speziel- len Lagers	Abb.	Abmessungen						Käfig	Scheiben	Gewicht	Tragzahl	
		d	D	B	C	d ₁	R				dynamisch C _r ^{*1)}	statisch C _{or} ^{*1)}
		[mm]								[g]	[N]	
VLM 017	13	8	26	7	-	23	-	J	2ZR	18,4	2 500	1 340
VLM 062		10	30	8	-	26,8	-	TNH	2ZR	28,05	4 580	1 970
VLM 074		10	35	9	-	31,8	-	J	2ZR	49,04	4 500	3 370
VLM 121	14	8	22	7	-	20,2	-	J	2RSR	11,18	2 500	1 340
VLM 033		8	23	7	-	21,5	-	J	2RSR	12,9	2 500	1 340
VLM 111		10	30	8	-	26,8	-	J	2RSR	28,02	4 500	3 370
VLM 046		10	30	9	-	28	-	J	2RSR	32,05	5 100	2 370
VLM 051		10	32	9	-	29,7	-	J	2RSR	38,38	5 100	2 370
VLM 052		12	35	10	-	31	-	J	2RSR	45,03	6 100	3 090
VLM 079		15	40	11	-	35,6	-	TNH	2RSR	64,8	5 950	3 730
VLM 065	15	7,8	16	5	50	-	-	TNH	-	22,28	1 430	735
VLM 066		7,8	16	5	58	-	-	TNH	-	22,28	1 430	735
VLM 018♦		19	35	18	49	-	-	J	2ZR	152,4	6 100	3 100
VLM 019	16	6,1	25	7	10	10,5	-	TNH	2ZR	19,9	2 500	1 340
VLM 099		8	24	7	10	-	-	TNH	2ZR	16,33	2 800	1 530
VLM 020♦		8	32	8	14	13,3	26	TNH	2ZR	40,5	3 350	1 430
VLM 021♦	17	7,2	24	8	9	-	-	-	-	23,6	4 770	2 400
VLM 054	18	6	16	5	-	-	-	TNH	2ZR	4,47	1 480	610
VLM 022♦		12	22	8	-	-	-	TNH	2Z	10,3	2 690	1 290
VLM 023♦	19	16	30	8	-	-	-	TNH	2RSR	21,3	3 190	1 870
VLM 024♦	20	8	22	7	-	-	11	TNH	2RSR	10,7	2 500	1 340
VLM 025♦	21	8,2	28	8	30	-	-	J	2ZR	39	5 100	2 370
VLM 026♦	22	5	21	6	6,5	-	-	TNH	PZ	6,2	2 640	1 130
VLM 109	23	7	19	10	18	-	-	TNH	2ZR	16,7	2 850	1 070
VLM 027♦		7	19	11	18	-	-	TNH	2ZR	16,7	2 850	1 070
VLM 028♦		7	19	11	18	-	-	TNH	2ZR	16,5	2 850	1 070
VLM 029♦	24	10	27	8	32	17	-	TNH	ZR	49,9	5 100	2 370
VLM 030♦	25	12	36	10	-	1,5	-	J	2ZR	53,8	6 890	3 090
VLM 035♦		12	36	10	-	-	-	J	2ZR	54,4	6 100	3 100
VLM 032♦	26	8	22	7	11	14	-	-	-	7,5	3 790	2 120

Nach Auftrag Spezielle Lager und Rollen

Bezeichnung des speziel- len Lagers	Abb.	Abmessungen						Käfig	Scheiben	Gewicht	Tragzahl	
		d	D	B	C	d ₁	R				dynamisch C _r ^{*1)}	statisch C _{or} ^{*1)}
		[mm]								[g]	[N]	
VLM 092	49	6	24	7	8	-	-	TNH	ZR	16,98	2 500	1 340
VLM 093	50	8	26	7	-	23,6	-	J	2ZR	18,04	2 500	1 340
VLM 100	51	8	24	7	-	-	-	J	2ZR	15,83	2 500	1 340
VLM 095		8	26	7	-	-	-	J	2ZR	20,03	2 500	1 340
VLM 116	52	8	44	10	11	-	-	-	-	88,6	5 860	3 820
VLM 120	53	8	44	10	12	-	-	-	-	91,8	5 860	3 820
VLM 124	54	6	16,5	6	12	-	-	TNH	ZR	8,35	-	-
VLM 117	55	7	40	10	11	-	-	-	-	90,16	5 860	3 820
VLM 118	56	7	40	13	15	-	-	-	-	120,21	5 860	3 820
VLM 122		8	51	11	12	-	-	-	-	165,08	8 260	6 170
VLM 123		8	67	14,5	16	-	-	-	-	386,93	8 260	6 170
VLM 103	57	8	28	8	14	-	-	J	2ZR	33,82	4 500	2 240
VLM 112		12,86	28,6	8	11,1	-	-	J	2ZR	24,42	4 500	2 240
VLM 107	58	12	39	15,9	-	41,3	5	2TNH	2ZR	83,38	7 800	4 400

Notiz.: Formausführung der einzelnen Rollen ist auf den folgenden Seiten abgebildet

Rollen mit Bezeichnung (♦) werden nicht laufend produziert, ihre Lieferung muss im voraus vereinbart werden

Beschriftung :

- Falls das Lager als eine Rolle verwendet wird, vermindern sich die Werte der Tragzahlen C_r und C_{or} auf 2/3 der in der Tabelle angegebenen Werte.
- Lager mit beiderseitigen Deckscheiben (-2ZR,-2RSR) sind mit Kunststoffschmiermittel gefüllt.
- Bei den meisten nach Auftrag gefertigten Rollen mit Deckungen kann Austausch der Deckungen gegen Dichtungen und umgekehrt durchgeführt werden.

Nach Auftrag Spezielle Lager und Rollen

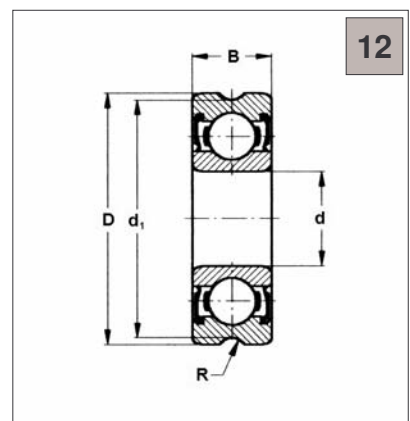
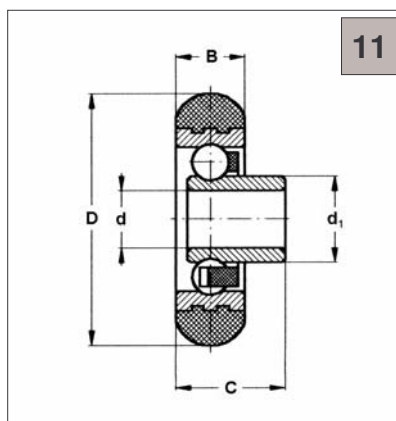
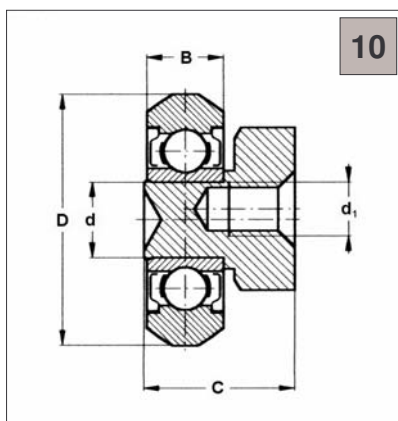
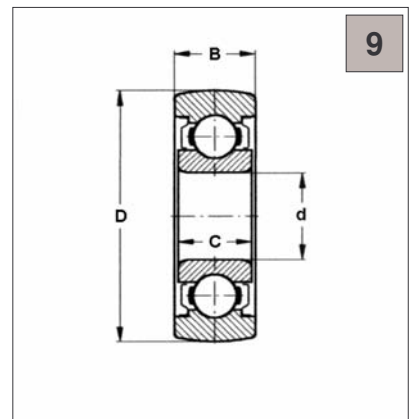
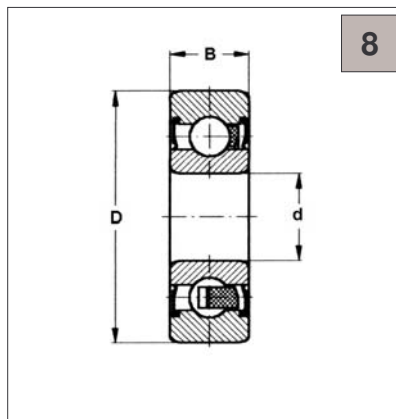
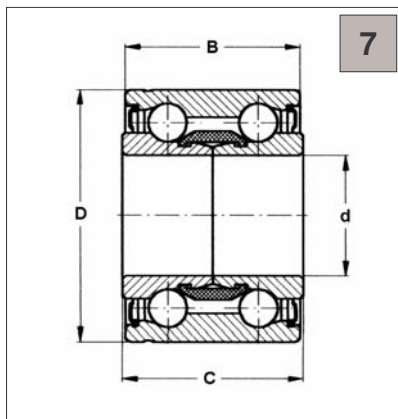
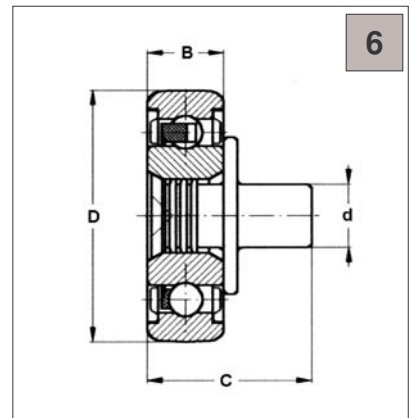
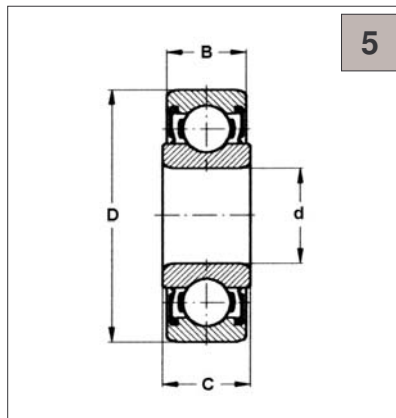
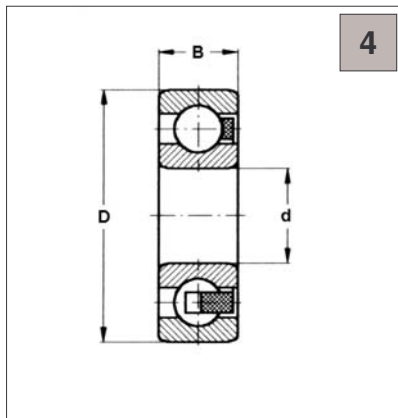
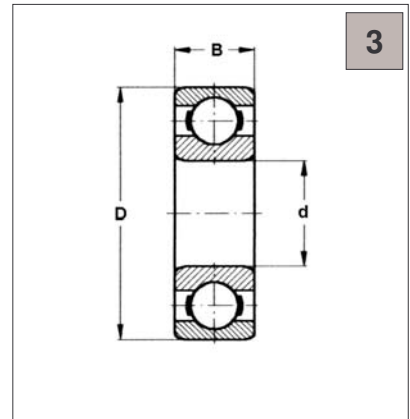
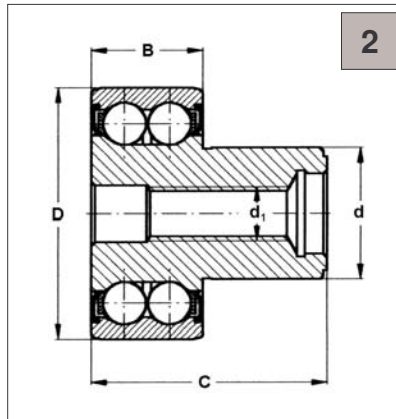
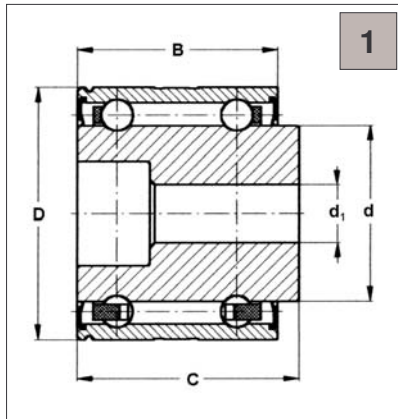

Nach Auftrag Spezielle Lager und Rollen

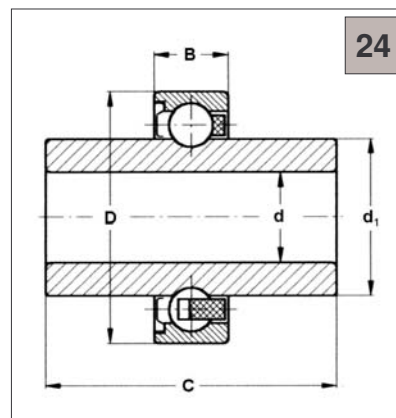
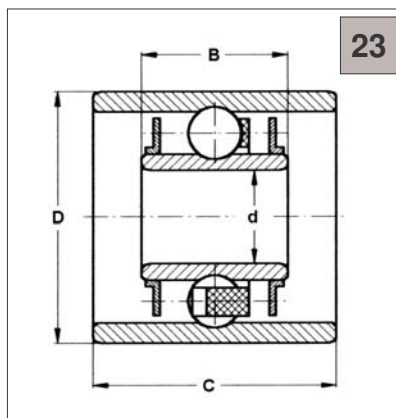
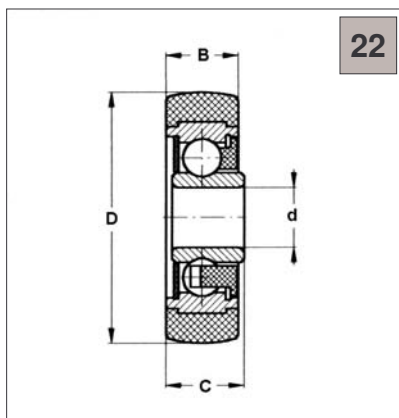
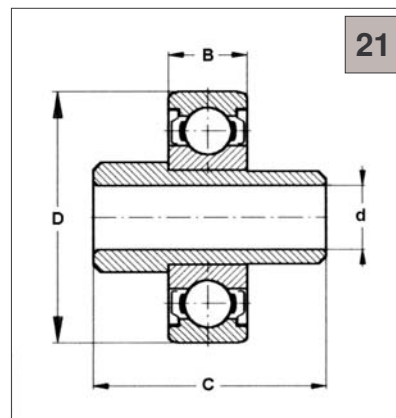
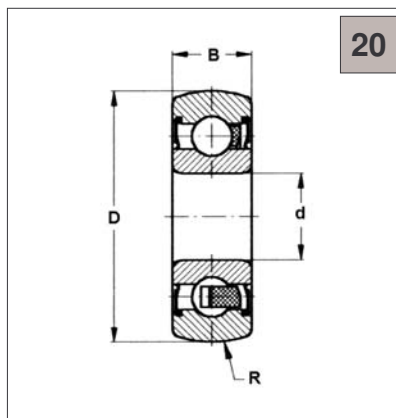
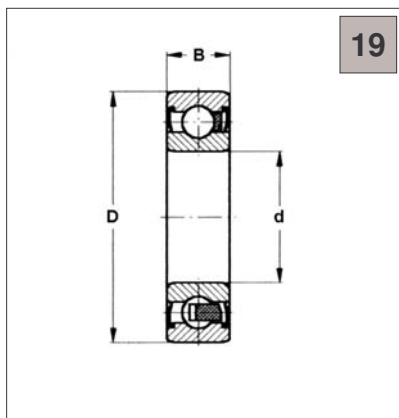
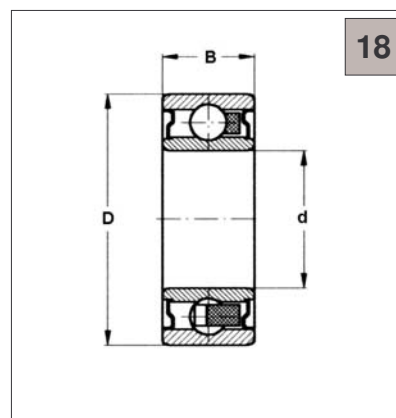
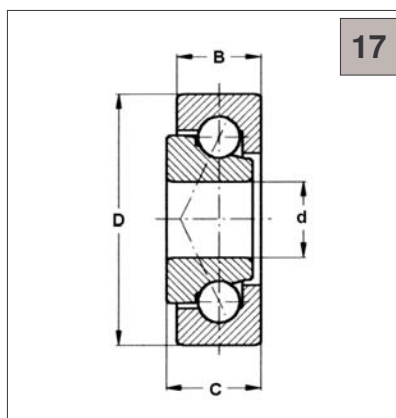
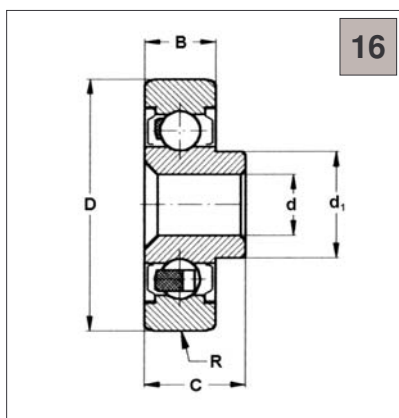
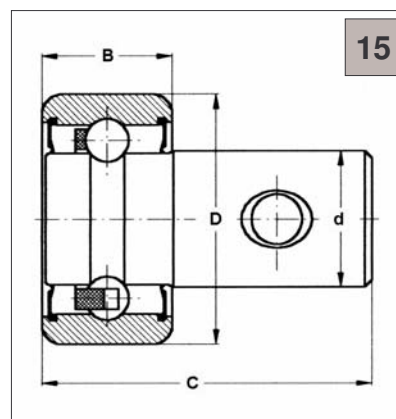
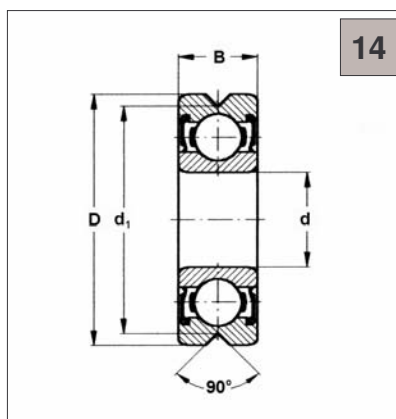
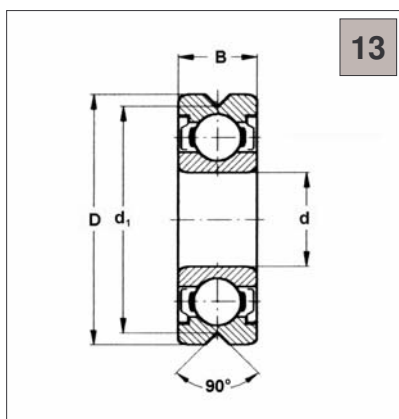

Nach Auftrag Spezielle Lager und Rollen

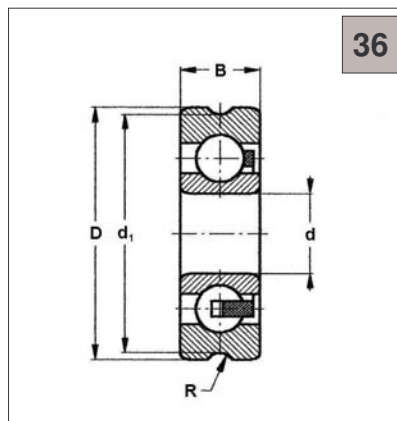
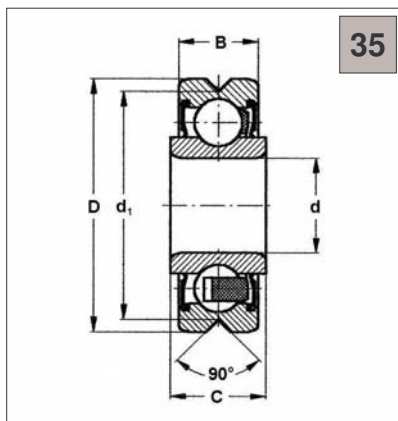
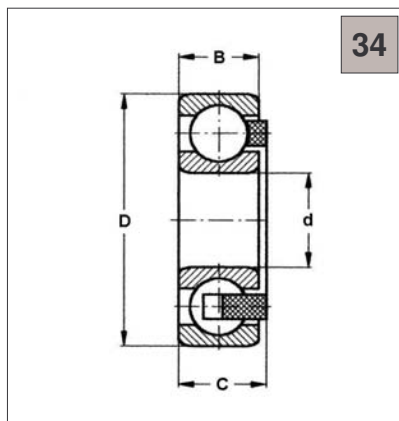
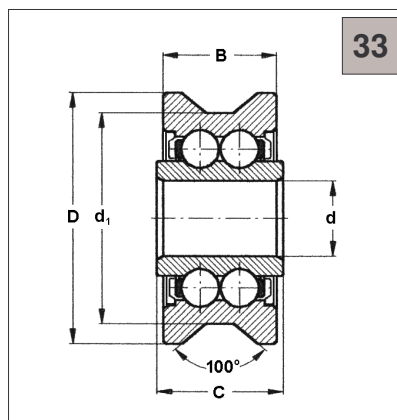
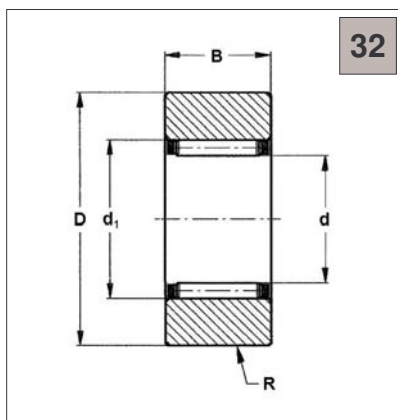
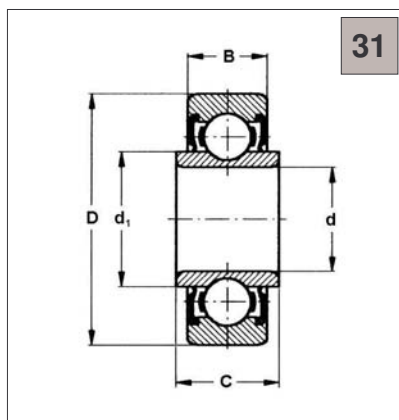
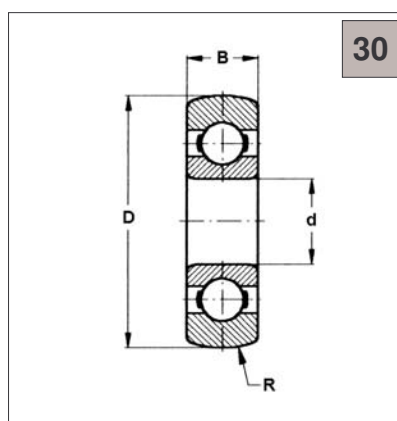
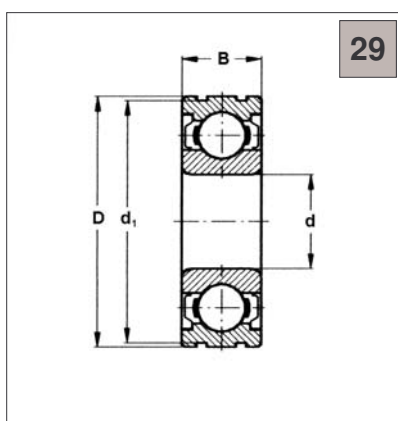
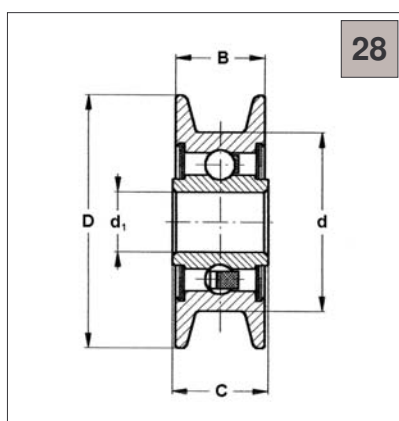
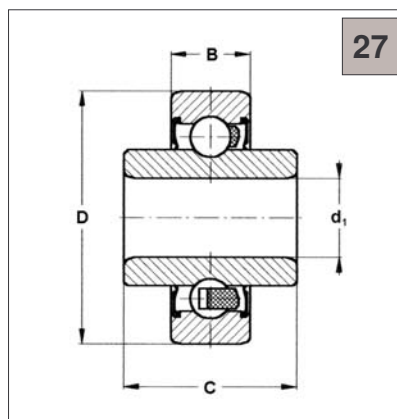
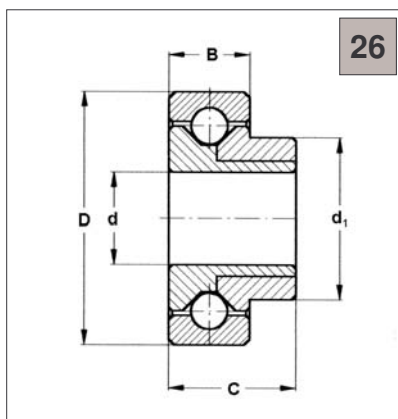
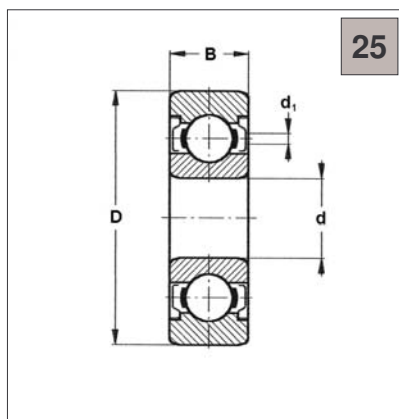

Nach Auftrag Spezielle Lager und Rollen

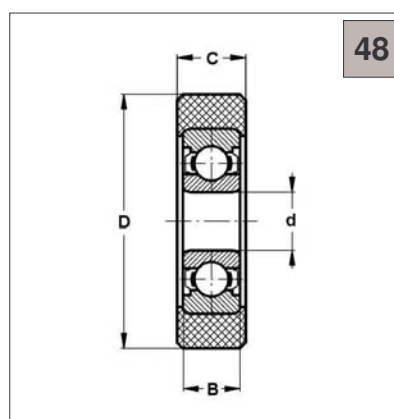
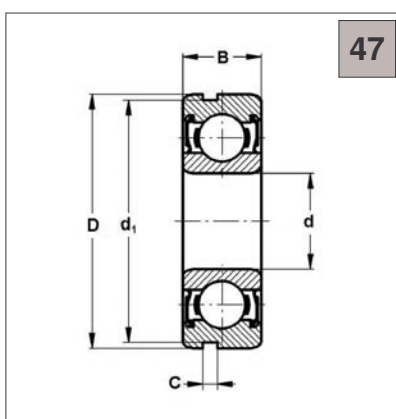
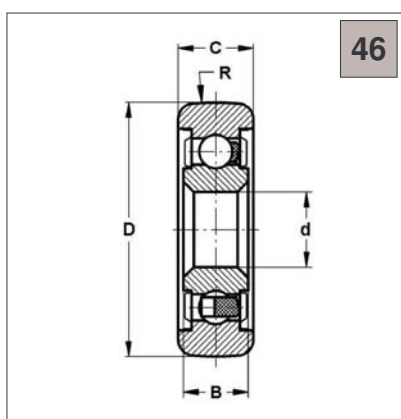
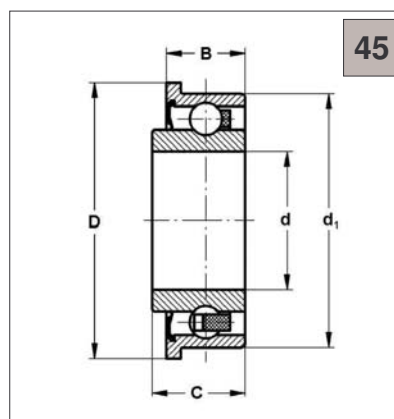
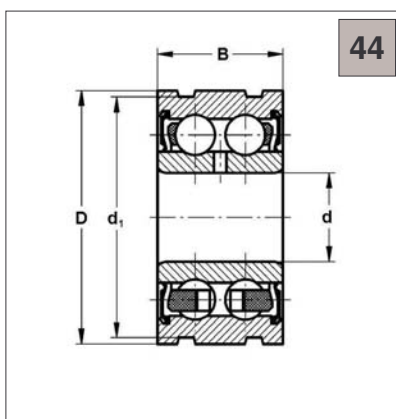
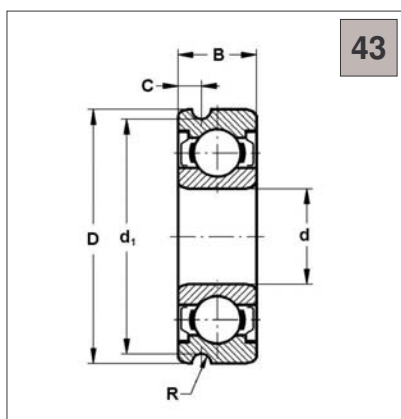
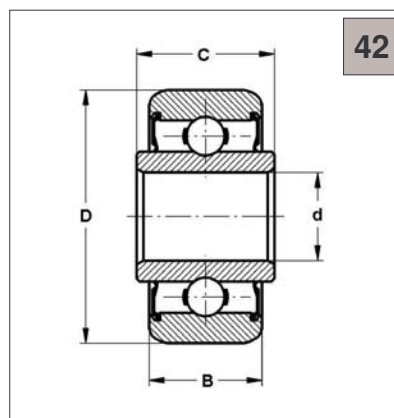
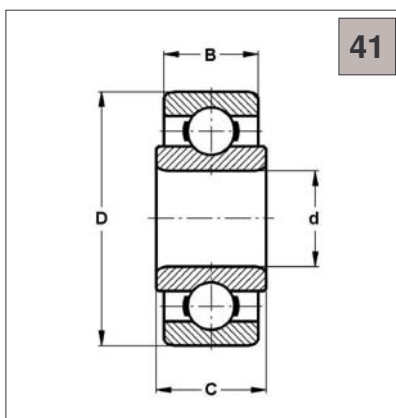
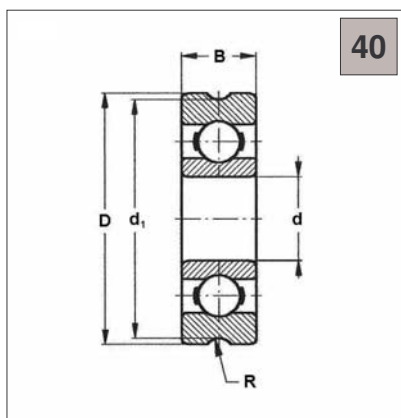
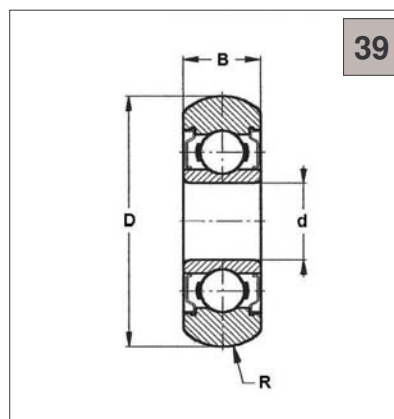
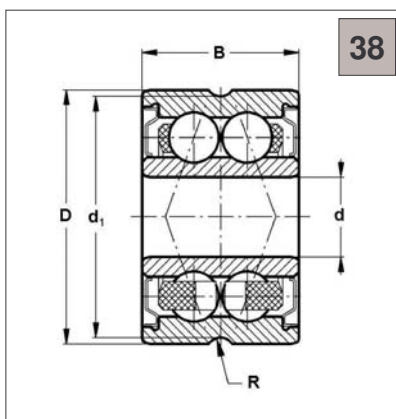
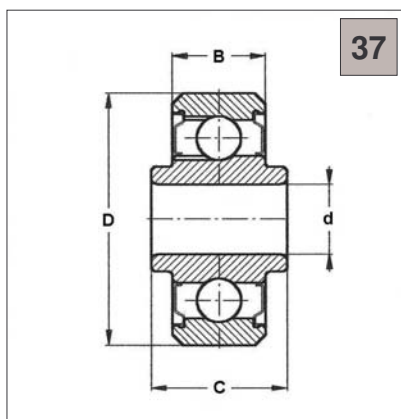

Nach Auftrag Spezielle Lager und Rollen

